

English - November 2017

Introduction

This installation guide provides instructions for installation, startup, and adjustment. To receive a copy of the Instruction Manual, contact your local Sales Office or view a copy at www.fisher.com. For further information refer to: EZH and EZHSO Series Pressure Reducing Regulators Instruction Manual, D103077X012.

P.E.D. Categories

This product may be used as a pressure accessory with pressure equipment in the following Pressure Equipment Directive categories. It may also be used outside of the Pressure Equipment Directive using sound engineering practice (SEP) per table below. For information on the current PED revision see Bulletin: [D103053X012](#)

TYPE	PRODUCT SIZE	BODY MATERIAL	CATEGORY
EZH	DN 25, 50, 80 and 100 / NPS 1, 2, 3 and 4	WCC Steel	IV
EZHSO	DN 25, 50 and 80 / NPS 1, 2 and 3	WCC Steel	IV
EZHOSX	DN 25, 50, 80 and 100 / NPS 1, 2, 3 and 4	LCC Steel	IV
EZHSO-OSX	DN 25, 50 and 80 / NPS 1, 2 and 3	LCC Steel	IV

Specifications

Available Configurations

Type EZH (Spring-to-Close): Pilot-operated pressure reducing regulator for low to high outlet pressure

Type EZHSO (Spring-to-Open): Pilot-operated pressure reducing regulator for low to high outlet pressure

Type EZHOSX: Type EZH with a Type OS2 slam-shut device for overpressure (OPSO) or overpressure and underpressure (OPSO/UPSO) protection

Type EZHSO-OSX: Type EZHSO with a Type OS2 slam-shut device for overpressure (OPSO) or overpressure and underpressure (OPSO/UPSO) protection

Body Sizes, End Connection Styles and Pressure Ratings⁽¹⁾

See Table 1

Maximum Inlet and Outlet (Casing) Pressures⁽¹⁾

103 bar / 1500 psig

Maximum Emergency (Design Casing Pressure)⁽¹⁾

103 bar / 1500 psig

Maximum Operating Differential Pressure⁽¹⁾⁽⁴⁾

Main Valve: 103 bar d / 1500 psid

Pilot: *Between loading pressure in pilot and loading sense pressure:* 85.0 bar d / 1233 psid

Outlet Pressure

See Table 2

Minimum Differential Pressures⁽¹⁾⁽²⁾

SERIES	MAIN VALVE BODY SIZE		MINIMUM DIFFERENTIAL			
			For 90% Capacity		For 100% Capacity	
	DN	NPS	bar d	psid	bar d	psid
EZH	25	1	1.1	15.2	1.1	15.7
	50	2	0.83	12.0	0.95	13.8
	80	3	0.73	10.6	0.88	12.8
	100	4	1.1	15.8	1.1	16.4
	150, 200, 300 X 150	6, 8, 12 X 6	----	----	0.97	14.0
EZHSO	25	1	3.8	55	3.8	55
	50	2				
	80	3				
	100	4	----	----	1.8	25.6
	150, 200, 300 X 150	6, 8, 12 X 6	----	----	0.97	14.0

Pressure Registration

External

Pilot Connections

1/4 NPT

Temperature Capabilities⁽¹⁾

Nitrile (NBR) Version:

-29 to 82°C / -20 to 180°F

Fluorocarbon (FKM) Version:

-18 to 82°C / 0 to 180°F⁽³⁾

Polyurethane (PU) Version:

DN 25, 50, 150, 200 and 300 X 150 / NPS 1, 2, 6, 8 and 12 X 6 Sizes:

-30 to 82°C / -22 to 180°F

DN 80 to 100 / NPS 3 to 4 Sizes:

-20 to 82°C / -4 to 180°F

Installation



WARNING

Only qualified personnel shall install or service a regulator. Regulators should be installed, operated and maintained in accordance with international and applicable codes and regulations and Emerson Process Management Regulator Technologies, Inc. instructions.

If the regulator vents fluid or a leak develops in the system, it indicates that service is required. Failure to take the regulator out of service immediately may create a hazardous condition.

Personal injury, equipment damage or leakage due to escaping fluid or bursting of pressure containing parts may result if this regulator is overpressured or is installed where service conditions could exceed the

1. The pressure/temperature limits in this Installation Guide and any applicable standard or code limitation should not be exceeded.
2. When using a Type SA/2 pilot supply filter regulator, the differential pressure across the regulator must be at least 3.1 bar d / 45 psid for optimum regulator performance.
3. Types PRX and SA/2 Fluorocarbon (FKM) elastomer is limited to -18°C / 0°F.
4. Maximum Operating Differential Pressure is 96.5 bar d / 1400 psid for DN 25 / NPS 1 EZHSO Series.

EZH and EZHSO Series

Table 1. Main Valve Body Sizes, End Connection Styles and Body Ratings

MAIN VALVE BODY SIZE		MAIN VALVE BODY MATERIAL	END CONNECTION STYLE	STRUCTURAL DESIGN RATING	
DN	NPS			bar	psig
25 and 50	1 and 2	LCC or WCC Steel	NPT or SWE	103	1500
			CL150 RF	20.0	290
25, 50, 80, 100, 150, 300 X 150 and 200	1, 2, 3, 4, 6, 12 X 6 and 8		CL300 RF	51.7	750
			CL600 RF or BWE	103	1500

Table 2. Outlet Pressure Ranges

TYPE	OUTLET PRESSURE RANGE		AC (ACCURACY CLASS)		PILOT CONTROL SPRING INFORMATION	
	bar	psig	EZH Series	EZHSO Series	Spring Color	Part Number
PRX/120 PRX/125	1.00 to 1.8 1.6 to 3.0 2.8 to 5.5 5.0 to 8.5	14.5 to 26 23 to 44 41 to 80 73 to 123	2.5%	2.5%	Yellow Green Blue Black	M0255240X12 M0255230X12 M0255180X12 M0255220X12
	8.0 to 14.5 14.0 to 23.0 22.0 to 30.0	116 to 210 203 to 334 319 to 435	1%	2.5%	Silver Gold Aluminum	M0255210X12 M0255200X12 M0255860X12
PRX/120-AP PRX/125-AP	30.0 to 80.0	435 to 1160	1%	2.5%	Clear	M0273790X12

limits given in the Specifications section or where conditions exceed any ratings of the adjacent piping or piping connections.

To avoid such injury or damage, provide pressure-relieving or pressure-limiting devices (as required by the appropriate code, regulation or standard) to prevent service conditions from exceeding limits.

Additionally, physical damage to the regulator could result in personal injury and property damage due to escaping fluid. To avoid such injury and damage, install the regulator in a safe location.

Clean out all pipelines before installation of the regulator and check to be sure the regulator has not been damaged or has collected foreign material during shipping. For NPT bodies, apply pipe compound to the external pipe threads. For flanged bodies, use suitable line gaskets and approved piping and bolting practices. Install the regulator in any position desired, unless otherwise specified, but be sure flow through the body is in the direction indicated by the arrow on the body.

Note

It is important that the regulator be installed so that the vent hole in the spring case is unobstructed at all times. For outdoor installations, the regulator should be located away from vehicular traffic and positioned so that water, ice and other foreign materials cannot enter the spring case through the vent. Avoid placing the regulator beneath eaves or downspouts and be sure it is above the probable snow level.

Overpressure Protection

The recommended pressure limitations are stamped on the regulator nameplate. Some type of overpressure protection is needed if the actual inlet pressure exceeds the maximum operating outlet pressure rating. Overpressure protection should also be provided if the regulator inlet pressure is greater than the safe working pressure of the downstream equipment.

Regulator operation below the maximum pressure limitations does not preclude the possibility of damage from external sources or debris in the line. The regulator should be inspected for damage after any overpressure condition.

Startup

The regulator is factory set at approximately the midpoint of the spring range or the pressure requested, so an initial adjustment may be required to give the desired results. With proper installation completed and relief valves properly adjusted, slowly open the upstream and downstream shutoff valves.

Adjustment

The adjustment of setpoint is performed using the pilot adjusting screw. To change the outlet pressure, loosen the jam nut and turn the adjusting screw clockwise to increase outlet pressure or counterclockwise to decrease it. Monitor the outlet pressure with a test gauge during the adjustment. Tighten the jam nut to maintain the desired setting.

Taking Out of Service (Shutdown)



To avoid personal injury resulting from sudden release of pressure, isolate the regulator from all pressure before attempting disassembly.

Parts List

EZH and EZHSO Series Main Valve (Figures 1 and 2)

Key	Description	Key	Description
1	Body	63*	O-ring
2	Seat Ring	64*	O-ring
3 ⁽¹⁾	Cage	66	Socket Head Set Screw
4*	Anti-Friction Ring	67	Crush Washer
5	Actuator Lower Casing	68	Special Screw
6	Cap Screws	69*	O-ring
7*	O-ring	70	Cap
8*	Anti-Friction Rings	71*	O-ring
9*	O-ring	72	Locking Nut
10	Pipe Plug		EZH Series
11	Actuator Upper Casing	73	Upper Spring Seat
13	Spring	74	Hex Socket Cap Screw
14	Sleeve	75*	O-ring
15*	O-ring	77	Screw
16	Socket Head Cap Screw	82	Lower Spring Seat
17*	O-ring	83	Ball Bearing
18	Inlet Plate	138	Travel Indicator Cover
19	Outlet Plate	139	Travel Indicator Stem
20*	Diaphragm	140	Indicator Bushing
21	Cap Screw	141	Travel Indicator Fitting
22	Plain Washer	142A*	O-ring
23	Hex Nut	142B*	O-ring
24	Continuous Thread Stud Bolt	143*	O-ring
25	Intermediate Flange	144	Spring Collet
26	Hex Nut	145	Retaining Ring
27	Sleeve Adaptor	146	Protective Cap
28*	O-ring	147	Stem
29*	O-ring	148	Upper Spring Seat
30*	Disk Holder Assembly	149	Lower Spring Seat
31	Disk Retainer	150	Ring Guide
32	Lock Washer	151	Stem Nut
33	Socket Head Cap Screw	152	Hex Nut
	EZH Series only	153	O-ring
34*	O-ring	154	Hex Socket Cap Screw
35	Bracket or Eyebolt	155	Stem Nut
36	Nameplate	156	Upper Spring Seat Adaptor
37	Drive Screw	157	Anti-friction ring
38	Travel Indicator Plug	158	O-ring
39	Long Bolt	159	Check valve
43	Caution/Warning Label	160*	Back-up ring
44	Adjusting Screw Cap	192	Travel Indicator Scale
59	Flow Arrow	193	Washer
60	Protective Cap	195	Pipe Plug
61	Sleeve Guide	196	Washer
62*	O-ring	197	Seat Adaptor
		198	O-ring

Mounting Parts (Figures 3 through 4)

Standard Configurations for Single Pilot and Working Monitor Pilots

Key	Description	Key	Description
46	Pipe Nipple	47	Pipe Nipple

Pre-Piped Pilot Supply Single-Pilot Configuration (with standard body or tapped inlet body)

Key	Description	Key	Description
47	Pipe Nipple	51	Pipe Cross
48	Tube Elbow (4 required)	52	Tubing
49	External Tube Connector		

Pre-Piped Pilot Supply and Pilot Exhaust Single-Pilot Configuration (with tapped inlet and outlet body)

Key	Description	Key	Description
47	Pipe Nipple	51	Pipe Cross
48	Tube Elbow (5 required)	52	Tubing
49	External Tube Connector	55	Internal Connector
50	Pipe Tee		

Pre-Piped Pilot Supply Working Monitor Pilot Configuration (with standard body or tapped inlet body)

Key	Description	Key	Description
47	Pipe Nipple	51	Pipe Cross
48	Tube Elbow	52	Tubing
49	External Tube Connector	54	Pipe Nipple
50	Pipe Tee		

Pre-Piped Pilot Supply and Pilot Exhaust Working Monitor Pilot Configuration (with tapped inlet and outlet body)

Key	Description	Key	Description
47	Pipe Nipple (2 required)	51	Pipe Cross
48	Tube Elbow (5 required)	52	Tubing
49	External Tube Connector (2 required)	53	90° NPT Pipe Elbow
50	Pipe Tee	54	Pipe Nipple
		55	Internal Connector

PRX Series Pilots (Figure 5)

Key	Description	Key	Description
1	Adjusting Screw	21	Lower Cover
2	Locknut	22*	Pad Holder
3	Cap	23	Stem
4*	Upper Cover O-ring	24	Nameplate
5*	O-ring	25*	Stem O-ring
6	Upper Spring Seat	26	Upper Diaphragm Nut
7	Spring	27	Damper Adjusting Screw with Hole
8	Upper Cover	28*	Restrictor/Damper O-ring
9	Lower Spring Seat	29	Damper/Restrictor Plate
10	Machine Screw	30	Ring Nut
11	Washer	31	Nameplate Screw
12	Filter	32	Restrictor Adjusting Screw with Hole
13	Upper Diaphragm Plate	33	Plug (Types PRX/125 and PRX/125-AP only)
14*	Diaphragm	34	Plug (Types PRX/125 and PRX/125-AP only)
15	Lower Diaphragm Plate	35	Spring Barrel Extension for AP
16	Body		
17*	Orifice O-ring		
18*	Lower Cover O-ring		
19	Orifice		
20	Nut		

Type SA/2 Pilot Supply Filter Regulators (Figure 6)

Key	Description	Key	Description
1	Spring	12*	Felt
2	Socket Head Cap Screw	13*	O-ring
3	Washer	14	Spring
4	Plate	15*	Pad Holder Unit
5	Regulator Seat	16	Nameplate
6*	O-ring	17	Screw Unit
7	Body	18*	Diaphragm
8	Filter Net	19	Regulator Cover
9	Washer	20	Spring Washer
10	Nut	21	Nut
11	Filter Cover		

*Recommended spare part

1. When retrofitting an EZH Series with pins with the new cage, it is also necessary to order the Seat Ring.

EZH and EZHSO Series

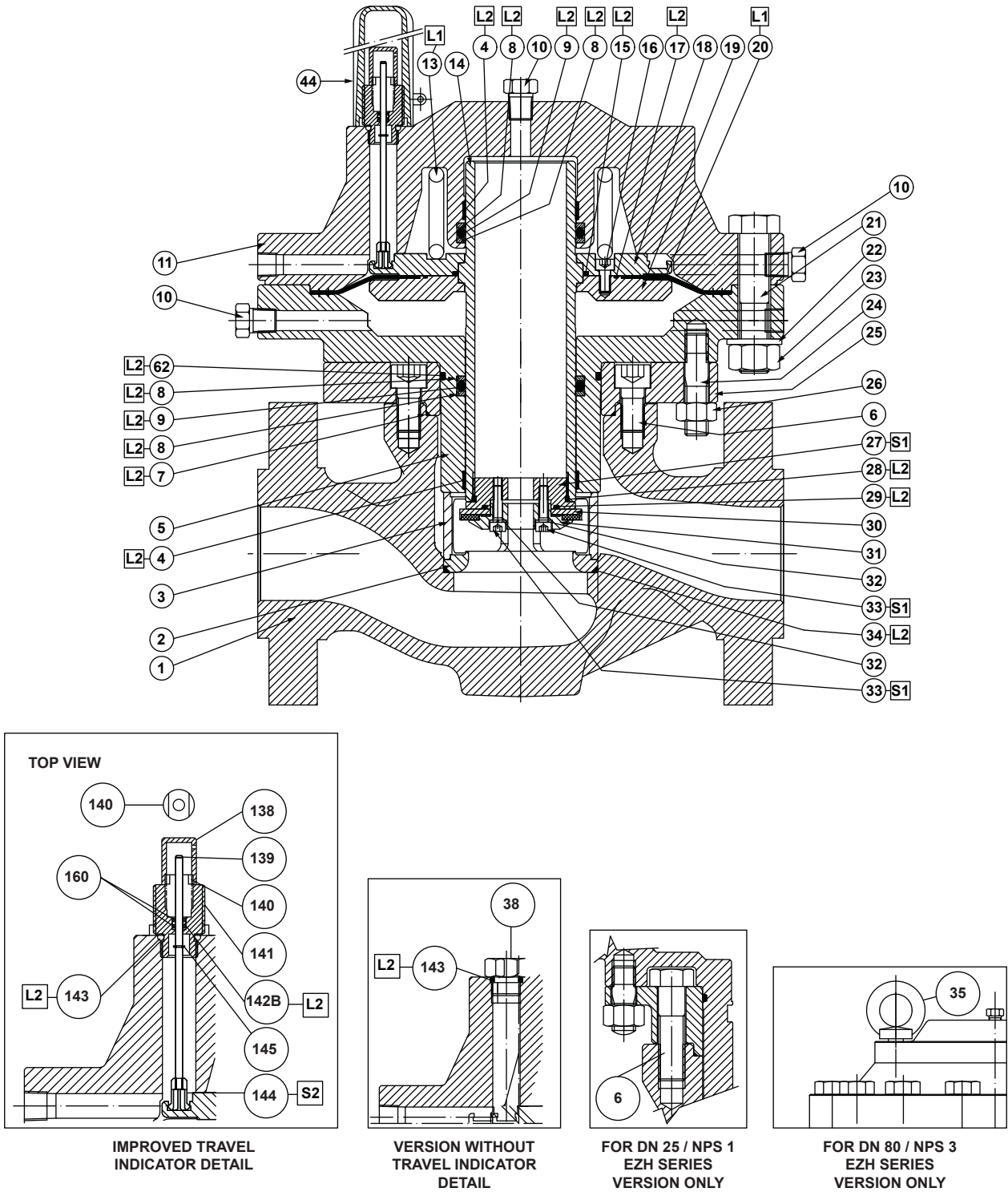

DN 25 THROUGH 80 / NPS 1 THROUGH 3

GD89918_H

□ APPLY LUBRICANT (L) / SEALANT (S)⁽¹⁾:

L1 = LITHIUM HYDROXYSTEGRATE NLGI 2 GRADE GREASE

L2 = SILICONE-BASED OR PTFE-BASED GREASE

S1 = ANAEROBIC METHACRYLATE SEALANT FOR NUTS AND BOLTS

S2 = ANAEROBIC METHACRYLATE SEALANT FOR THREADS

1. Lubricant and sealant must be selected such that they meet the temperature requirements.

Figure 1. EZH Series Main Valve Assembly

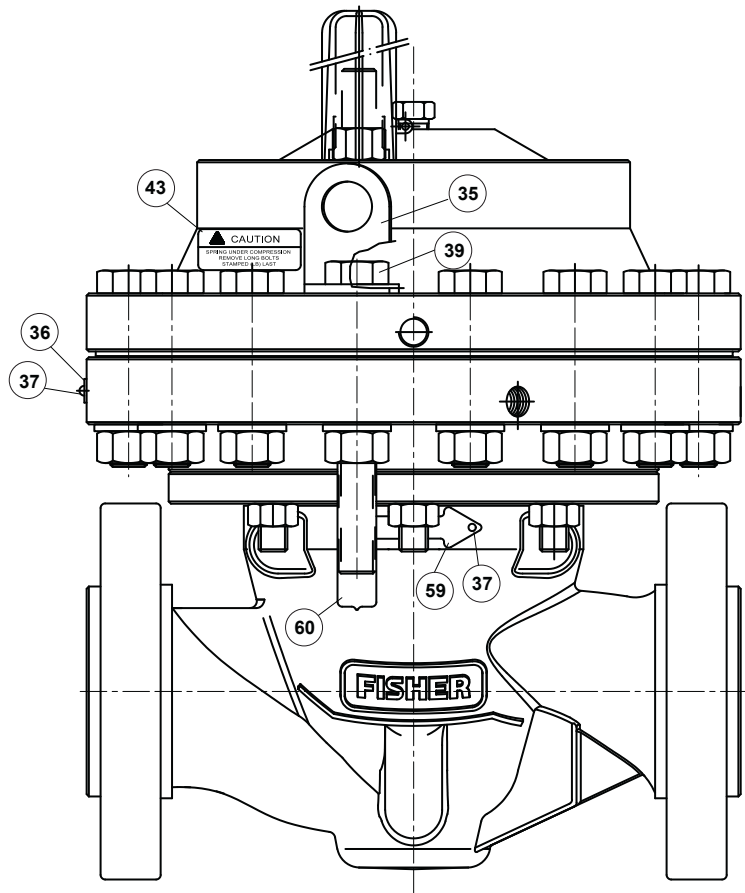

GD89918_J

DN 25 THROUGH 80 / NPS 1 THROUGH 3

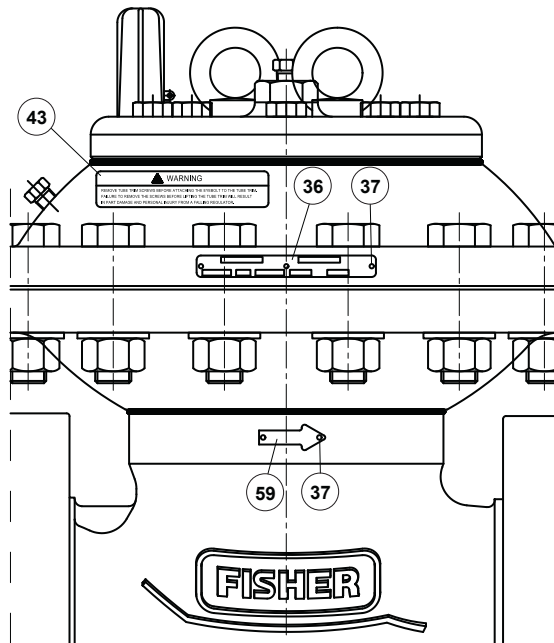

MLM1945_B

DN 100, 150, 200 AND 300 X 150 / NPS 4, 6, 8 AND 12 X 6

Figure 1. EZH Series Main Valve Assembly (continued)

EZH and EZHSO Series

TRAVEL INDICATOR DETAIL

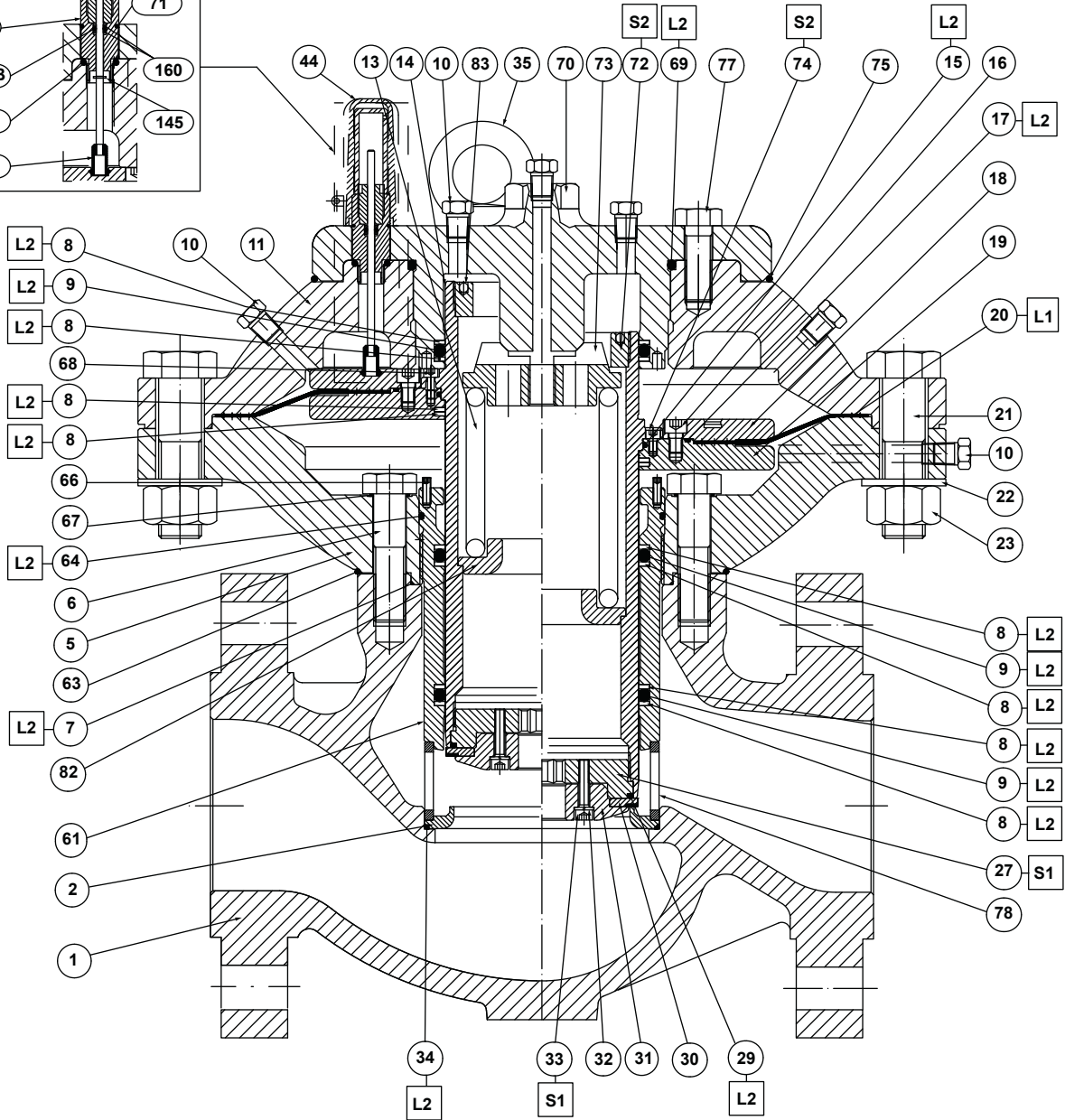
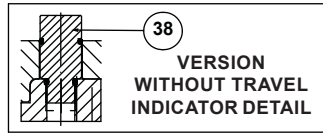
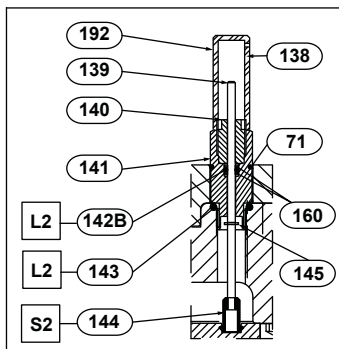

DN 100 / NPS 4

MLM1945_B

- APPLY LUBRICANT (L) / SEALANT (S)⁽¹⁾:
- L1 = LITHIUM HYDROXYSTEGRATE NLGI 2 GRADE GREASE
- L2 = SILICONE-BASED OR PTFE-BASED GREASE
- S1 = ANAEROBIC METHACRYLATE SEALANT FOR NUTS AND BOLTS
- S2 = ANAEROBIC METHACRYLATE SEALANT FOR THREADS

1. Lubricant and sealant must be selected such that they meet the temperature requirements.

Figure 1. EZH Series Main Valve Assembly (continued)

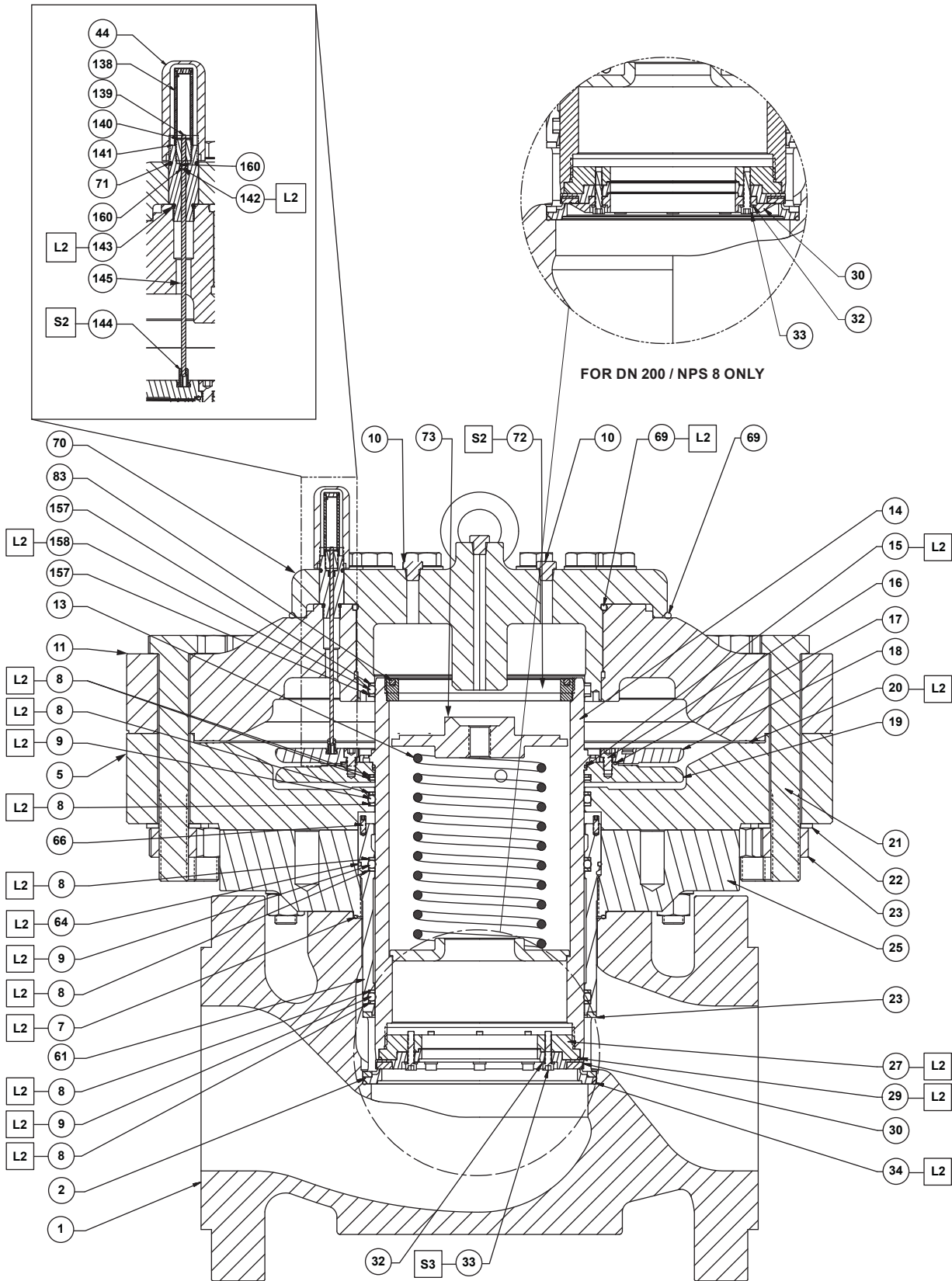

DN 150, 200, 300 X 150 / NPS 6, 8, 12 X 6

ERAA01010_AA

- APPLY LUBRICANT (L) / SEALANT (S)⁽¹⁾:
 - L2 = SILICONE-BASED OR PTFE-BASED GREASE
 - S2 = ANAEROBIC METHACRYLATE SEALANT FOR THREADS
 - S3 = GENERAL PURPOSE MEDIUM BOND STRENGTH THREADLOCKER

1. Lubricant and sealant must be selected such that they meet the temperature requirements.

Figure 1. EZH Series Main Valve Assembly (continued)

EZH and EZHSO Series

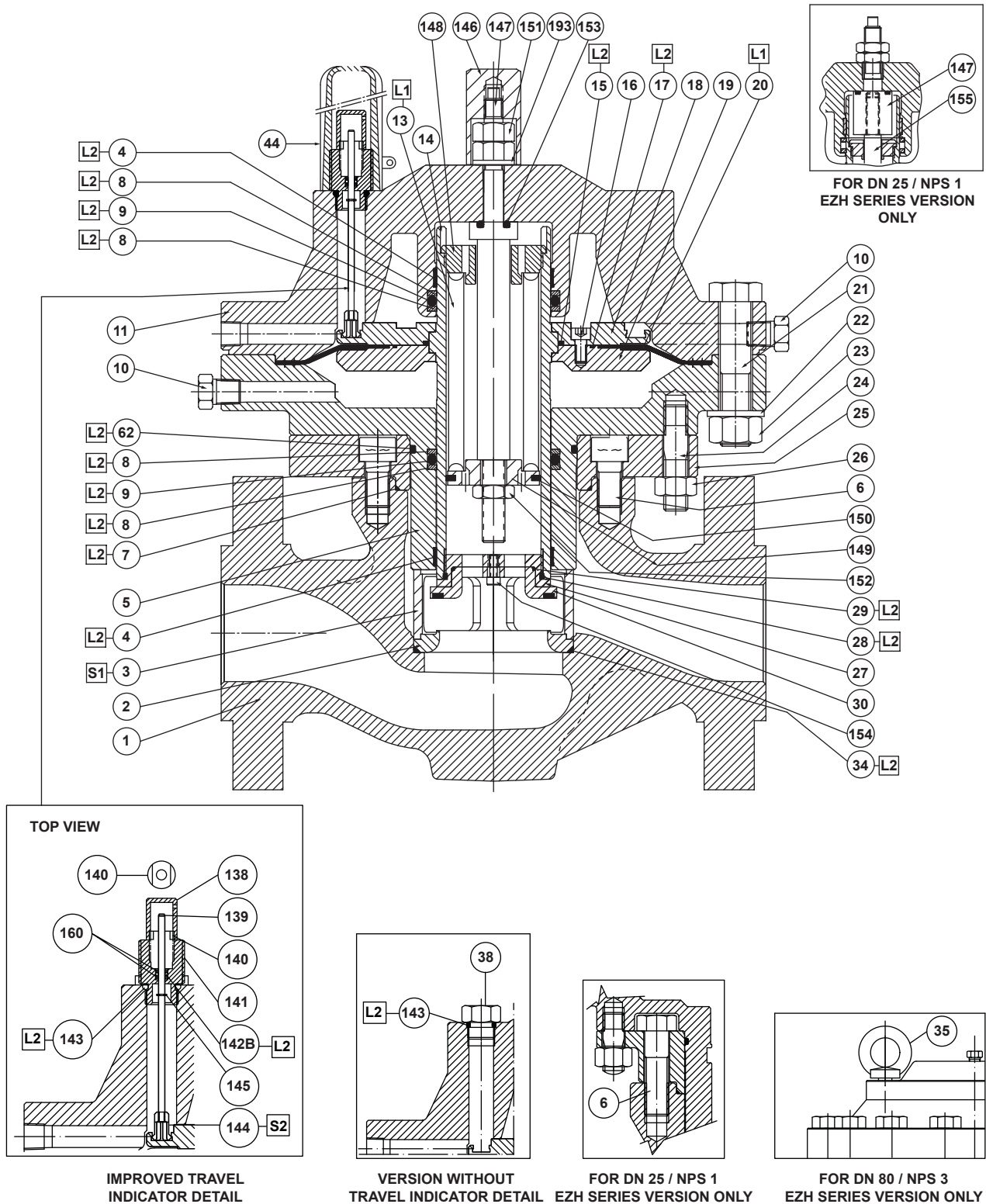

DN 25 THROUGH 80 / NPS 1 THROUGH 3

GE42373_D

- APPLY LUBRICANT (L) / SEALANT (S)⁽¹⁾:
- L1 = LITHIUM HYDROXYSTEGRATE NLGI 2 GRADE GREASE
- L2 = SILICONE-BASED OR PTFE-BASED GREASE
- S1 = ANAEROBIC METHACRYLATE SEALANT FOR NUTS AND BOLTS
- S2 = ANAEROBIC METHACRYLATE SEALANT FOR THREADS

1. Lubricant and sealant must be selected such that they meet the temperature requirements.

Figure 2. EZHSO Series Main Valve Assembly

TRAVEL INDICATOR DETAIL

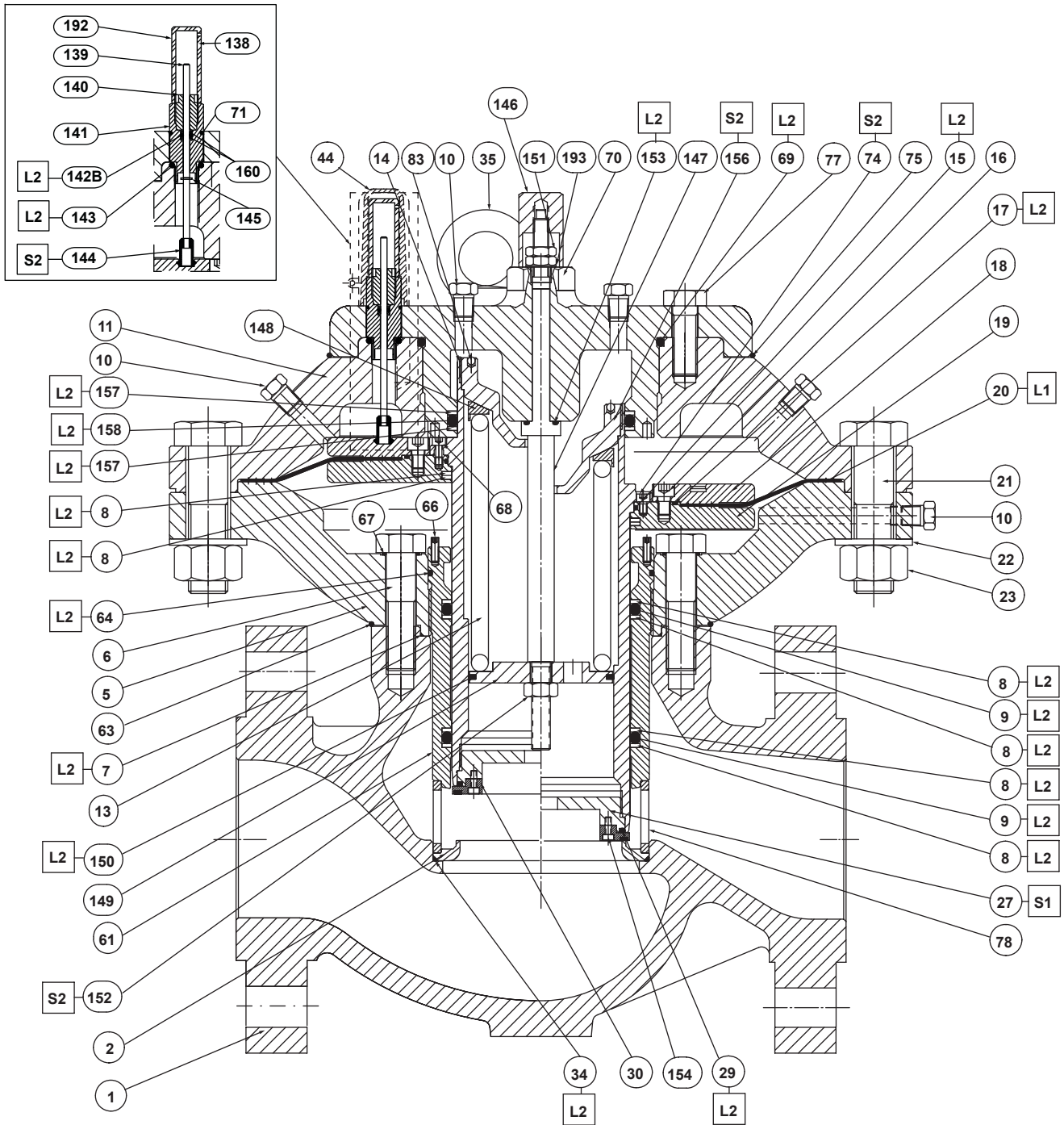

DN 100 / NPS 4

GE32477_D

- APPLY LUBRICANT (L) / SEALANT (S)⁽¹⁾:
- L1 = LITHIUM HYDROXYSTEGRATE NLGI 2 GRADE GREASE
- L2 = SILICONE-BASED OR PTFE-BASED GREASE
- S1 = ANAEROBIC METHACRYLATE SEALANT FOR NUTS AND BOLTS
- S2 = ANAEROBIC METHACRYLATE SEALANT FOR THREADS

1. Lubricant and sealant must be selected such that they meet the temperature requirements.

Figure 2. EZHSO Series Main Valve Assembly (continued)

EZH and EZHSO Series

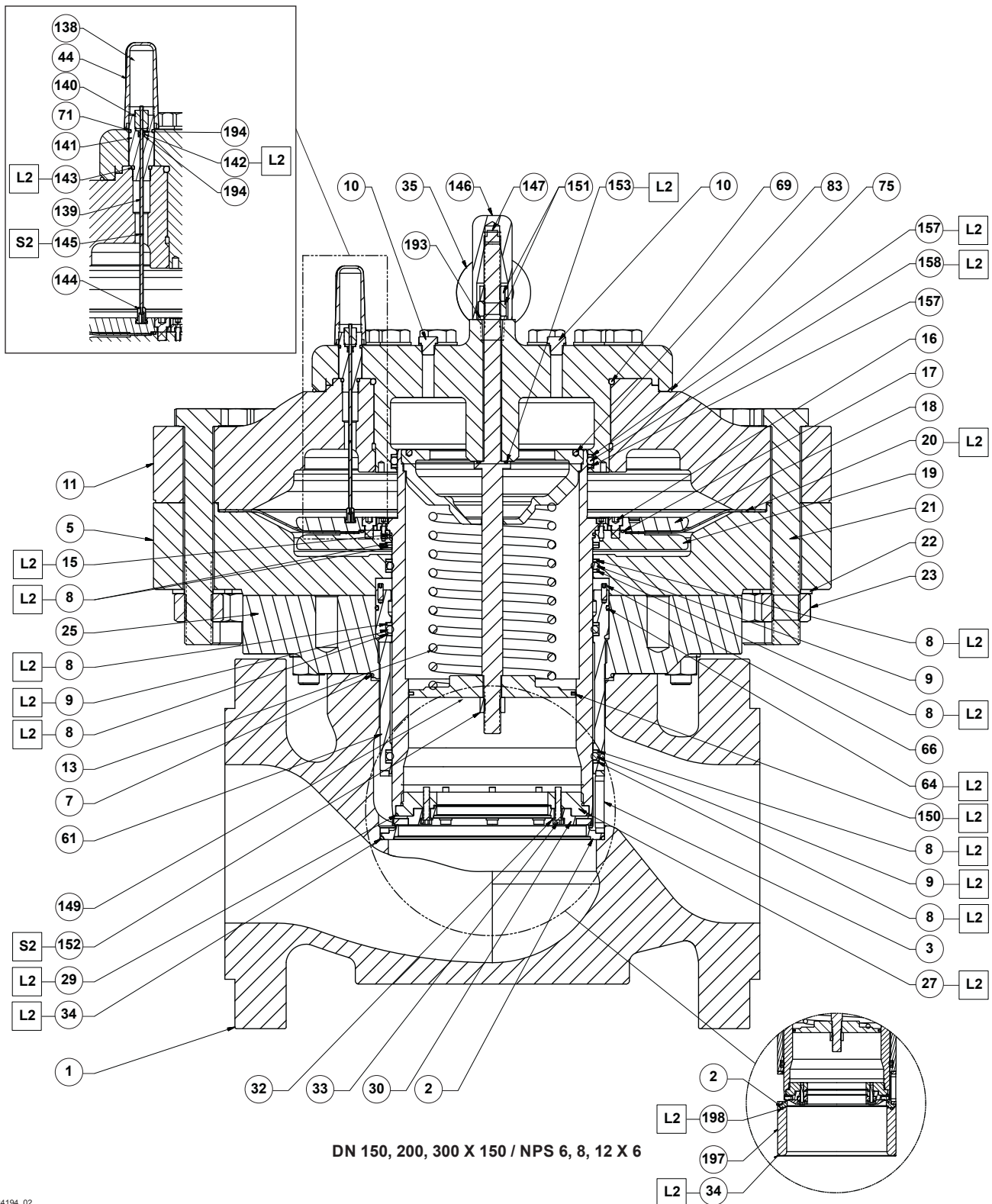

ERAA24194_02

□ APPLY LUBRICANT (L) / SEALANT (S)⁽¹⁾:
 L2 = SILICONE-BASED OR PTFE-BASED GREASE
 S2 = ANAEROBIC METHACRYLATE SEALANT FOR THREADS

1. Lubricant and sealant must be selected such that they meet the temperature requirements.

Figure 2. EZHSO Series Main Valve Assembly (continued)

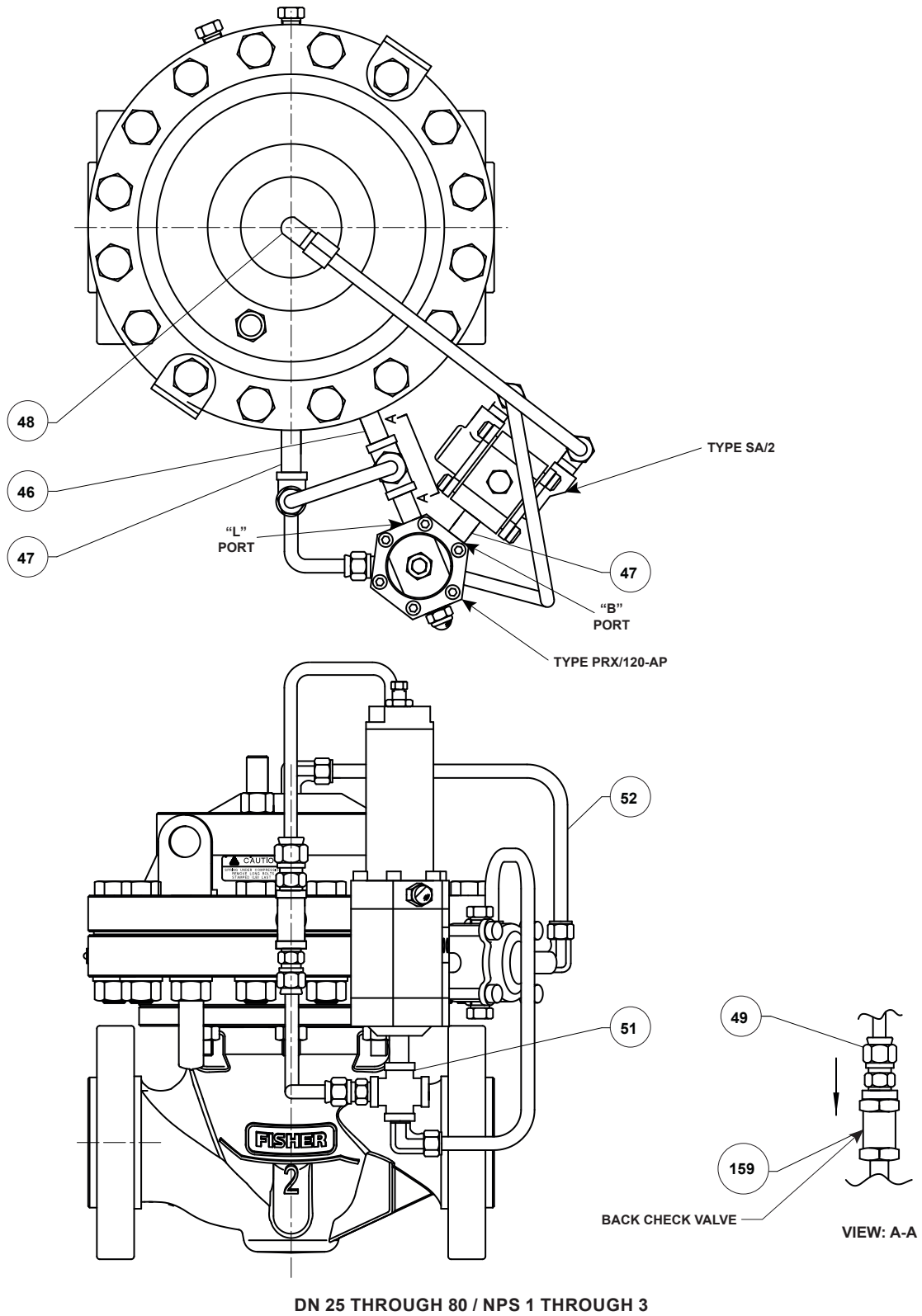

GE01727_E

Figure 3. EZH Series Single Pilot Mounting Assembly

EZH and EZHSO Series

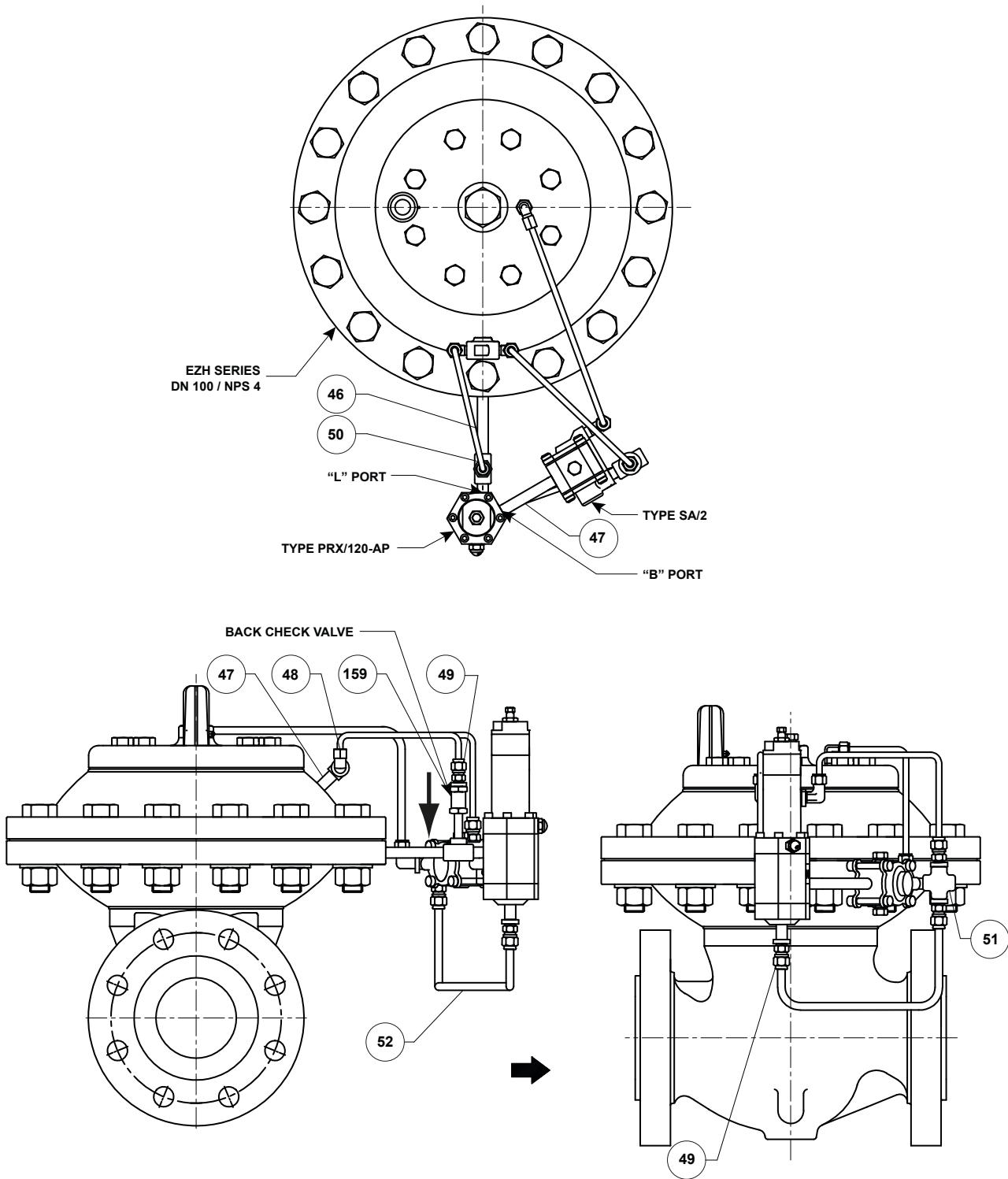

DN 100, 150, 200 AND 300 X 150 / NPS 4, 6, 8 AND 12 X 6

GE46932_C

Figure 3. EZH Series Single Pilot Mounting Assembly (continued)

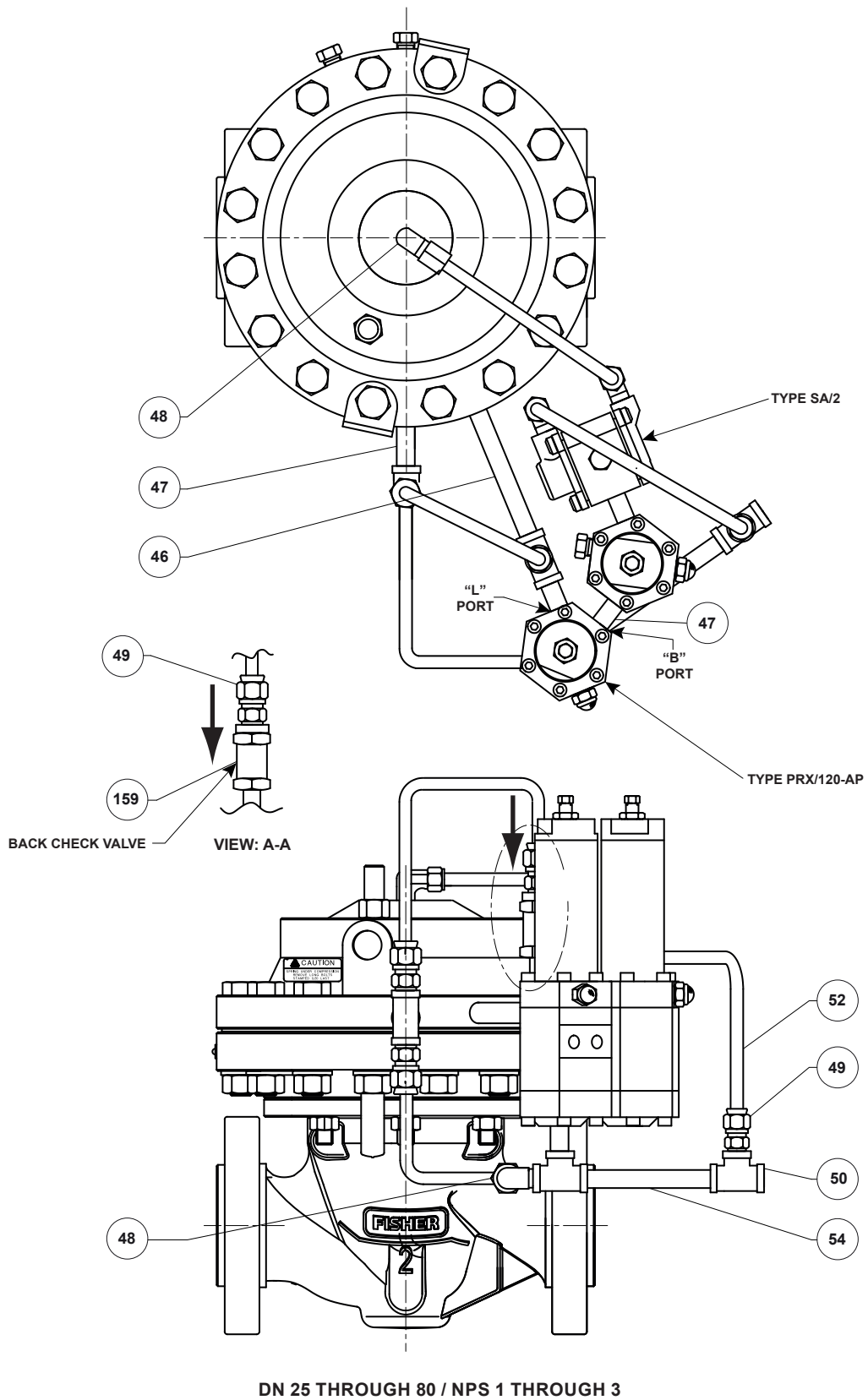

GE01790_D

Figure 4. EZH Series Working Monitor Pilot Mounting Assembly

EZH and EZHSO Series

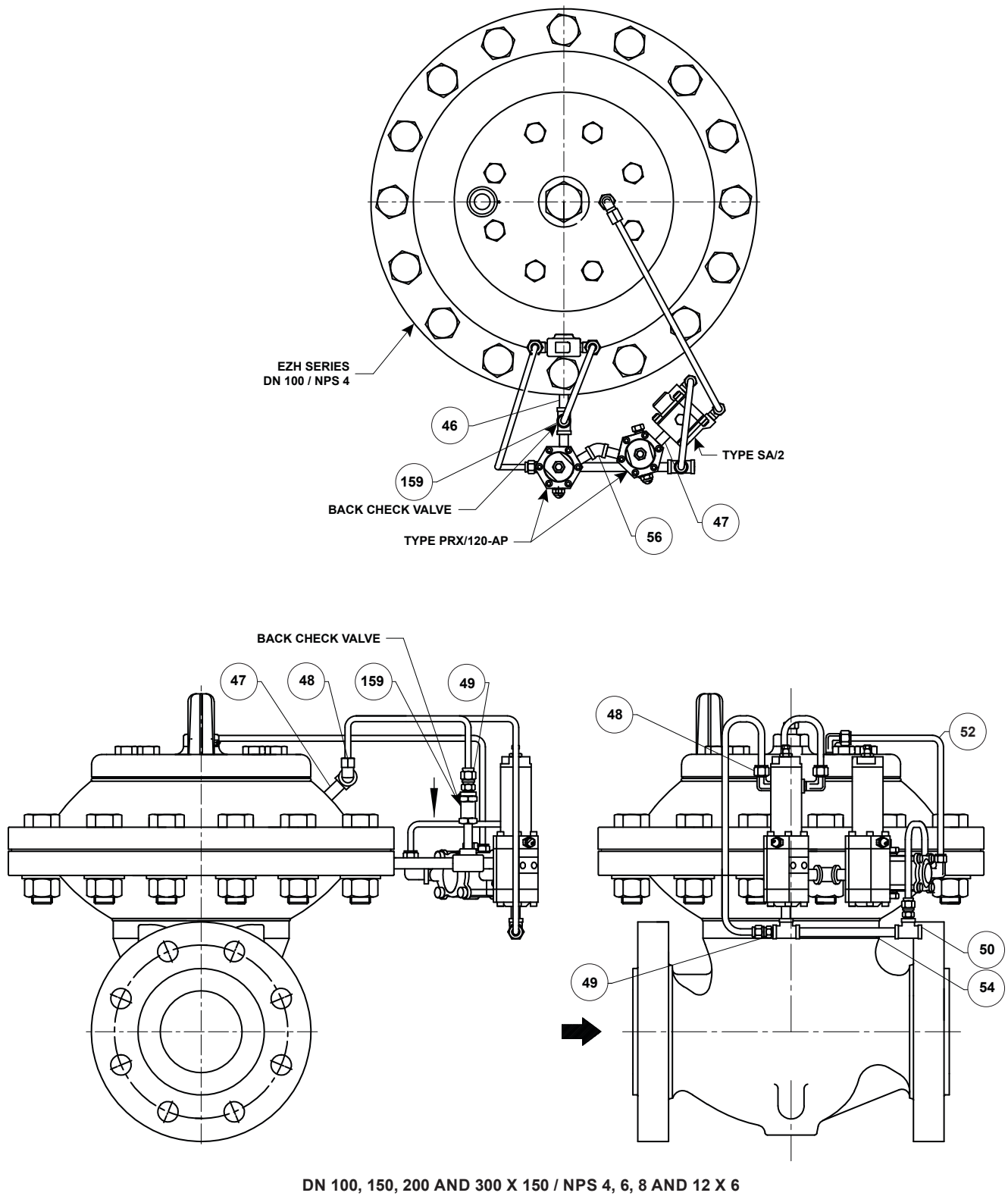

GE47004_B

Figure 4. EZH Series Working Monitor Pilot Mounting Assembly (continued)

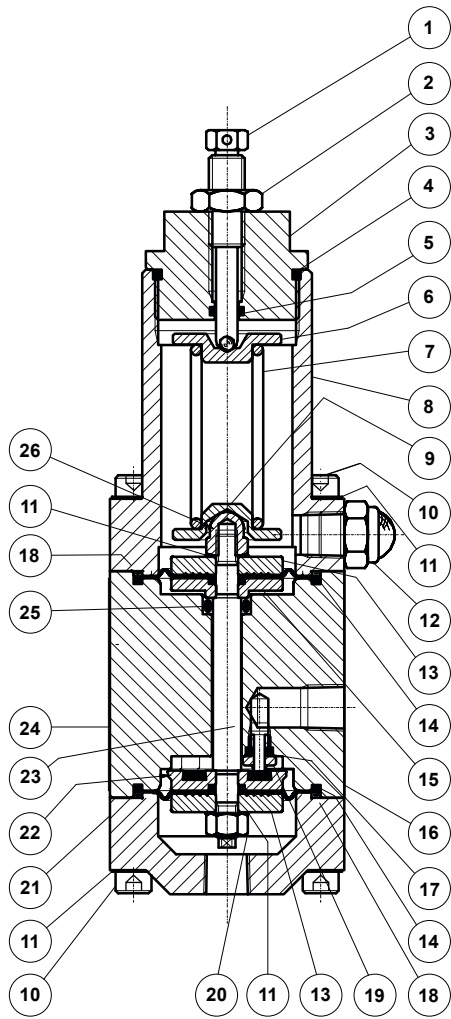

TYPE PRX/120 OR PRX/125

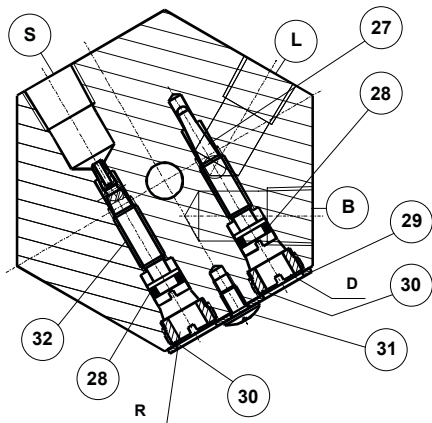

TYPE PRX/120 OR PRX/120-AP

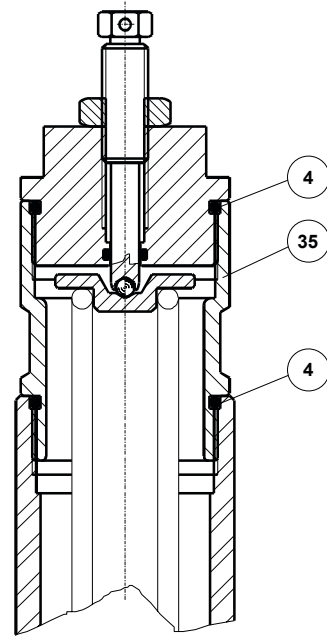

TYPE PRX/120-AP OR PRX/125-AP

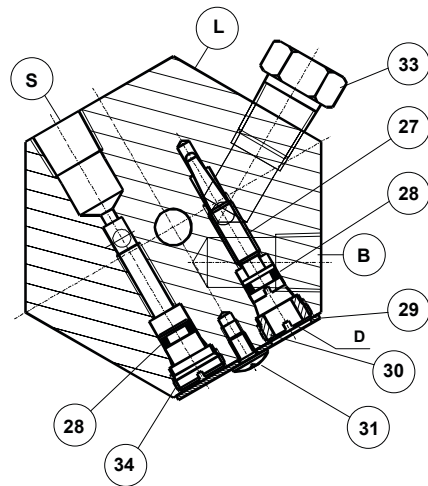

TYPE PRX/125 OR PRX/125-AP

- S - BLEED PORT
- B - SUPPLY PORT
- L - LOADING PORT
- A - SENSING PORT
- D - DAMPER
- R - RESTRICTOR

Figure 5. PRX Series Pilot Assemblies

EZH and EZHSO Series

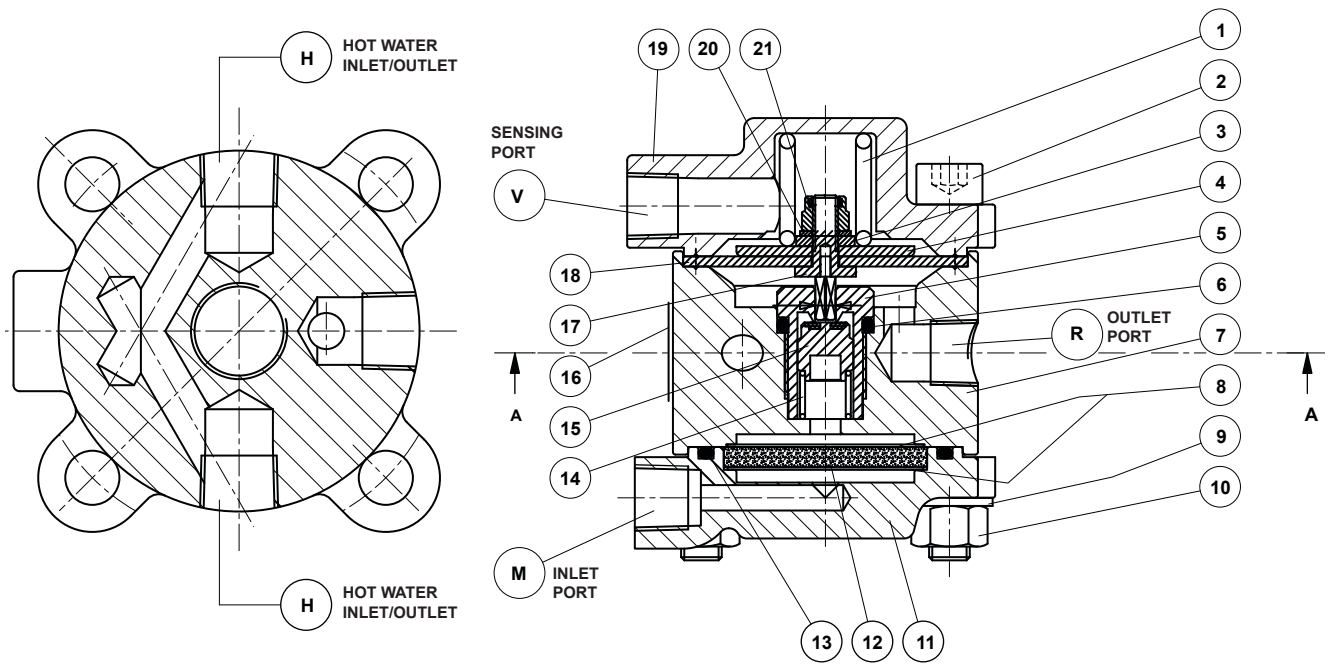

LM1162

Figure 6. Type SA/2 Pilot Supply Filter Assemblies

✉ Webadmin.Regulators@emerson.com

🔍 Fisher.com

📘 Facebook.com/EmersonAutomationSolutions

🌐 LinkedIn.com/company/emerson-automation-solutions

🐦 Twitter.com/emr_automation

Emerson Automation Solutions

Americas

McKinney, Texas 75070 USA
T +1 800 558 5853
+1 972 548 3574

Europe

Bologna 40013, Italy
T +39 051 419 0611

Asia Pacific

Singapore 128461, Singapore
T +65 6770 8337

Middle East and Africa

Dubai, United Arab Emirates
T +971 4 811 8100

D103077X014 © 2015, 2017 Emerson Process Management Regulator Technologies, Inc. All rights reserved. 12/17.

The Emerson logo is a trademark and service mark of Emerson Electric Co. All other marks are the property of their prospective owners. Fisher™ is a mark owned by Fisher Controls International LLC, a business of Emerson Automation Solutions.

The contents of this publication are presented for information purposes only, and while effort has been made to ensure their accuracy, they are not to be construed as warranties or guarantees, express or implied, regarding the products or services described herein or their use or applicability. All sales are governed by our terms and conditions, which are available on request. We reserve the right to modify or improve the designs or specifications of our products at any time without notice.

Emerson Process Management Regulator Technologies, Inc does not assume responsibility for the selection, use or maintenance of any product. Responsibility for proper selection, use and maintenance of any Emerson Process Management Regulator Technologies, Inc. product remains solely with the purchaser.



For further information on the current PED revision see Bulletin: [D103053X012](#) or scan the QR code.

